



Professional conveyor systems & intelligent pile turners

Presentation K&Z

K&Z company development & product portfolio

1. Company information
2. History
3. References (OEM's)
4. Contacts
5. Product portfolio
 1. Logistics
 2. Pile turner
6. Pictures

Pile turner and logistic for the packaging industry

History of the company

- 1993: Founded as Krifft & Zipsner GmbH
- 1998: Building of a new factory in Steinebach
- 2011: New factory building in Steinebach
- 2013: New factory building in Steinebach for electrical cabinet
- 2018: Significant expansion with an additional production hall and warehouse
- 2024: Cooperation partnership with robot system house aimed at opening up further markets



Plant I

Industriestraße 4

D-57520 Steinebach/Sieg

Tel.: +49 2747 92 40 0

E-Mail: info@krifft-zipsner.de

Internet: www.krifft-zipsner.de



Plant II

Industriestraße 17

D-57520 Steinebach/Sieg

References OEM's



Koenig & Bauer Group

KBA-Iberica Die Cutters



Pile turner and logistics for the packaging industry- our customers

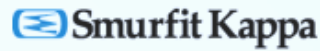
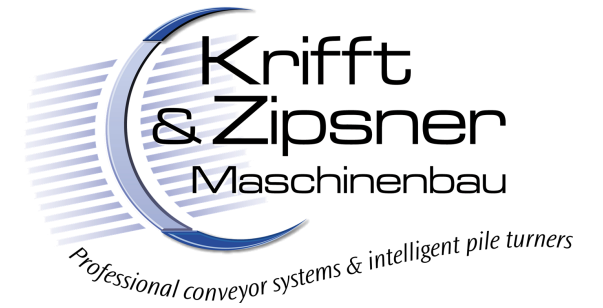

Contacts

CEO

René Eberz

Authorized officer

Frank Schmitt, Rainer Ehlert

Sales manager &
Projectmanagement

Rainer Ehlert

Mechanical design

Jürgen Utsch

Europe, Africa, Asia, Australia and Oceania

Service Hotline

+49 (1805) 575 201 (0,14 Ct./Min aus dem dt. Festnetz, Mobilfunk max. 42 Ct./Min)

E-Mail: hotline@krifft-zipsner.de

Transport

Patrick Breidling

Service hours of the hotline can be found

on our homepage

Service

Tim Greb

www.krifft-zipsner.de

Software

Benjamin Seibert

Product portfolio

Logistic system at the feeder and delivery of printing presses, die cutters and laminators

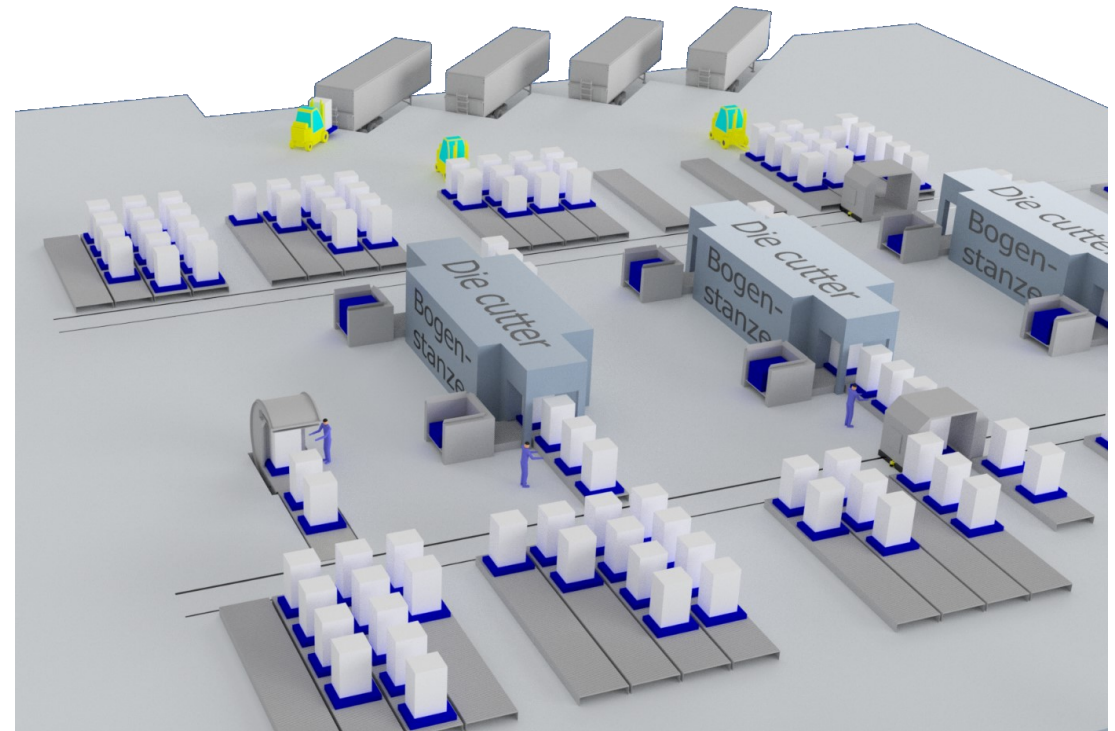
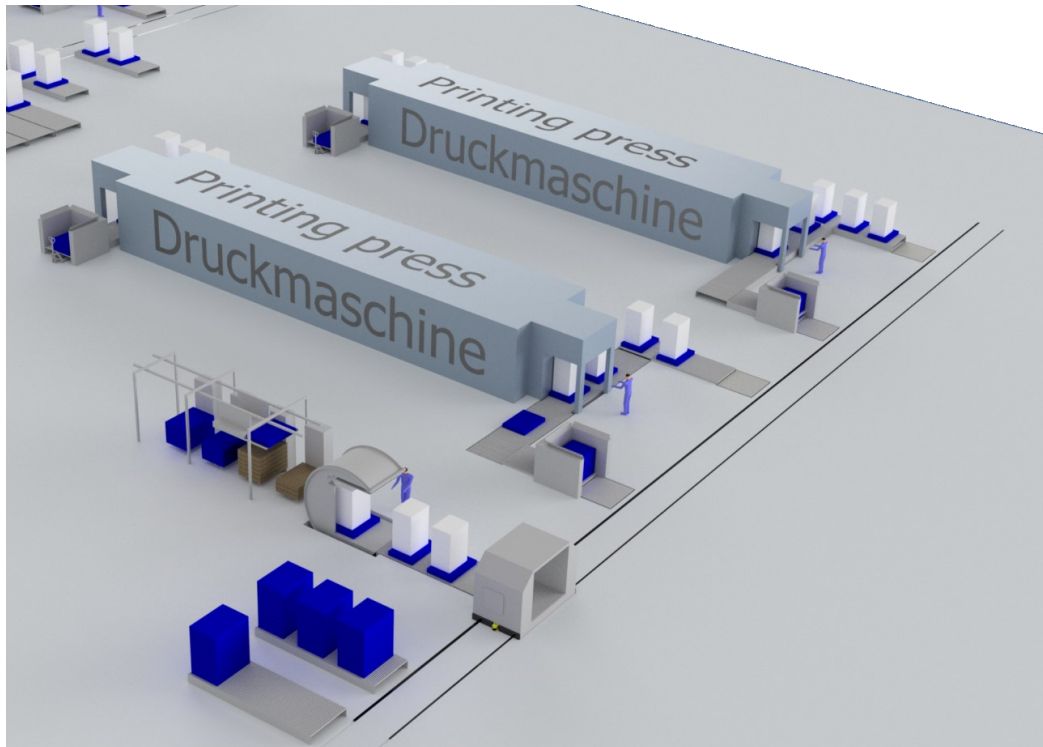

Product portfolio

Examples of our logistic portfolio, just a small overview

Roller conveyor

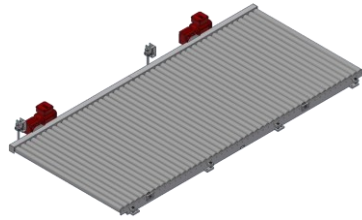

Tooth belt conveyor

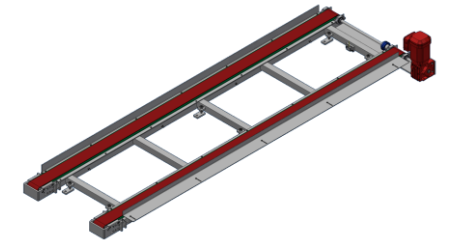

chain conveyor

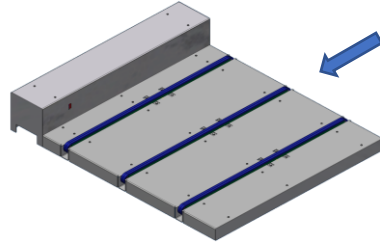

Corner transfer

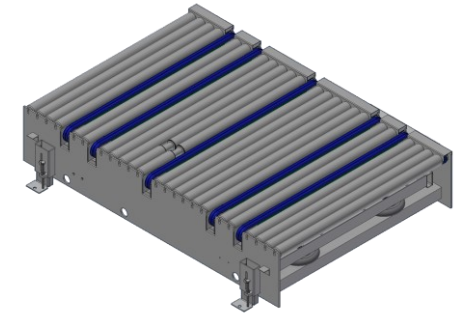

Plastic belt conveyor

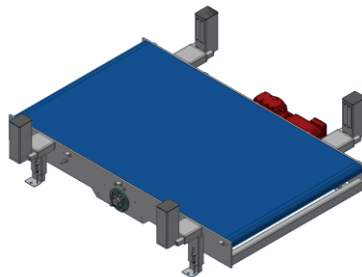

turntable

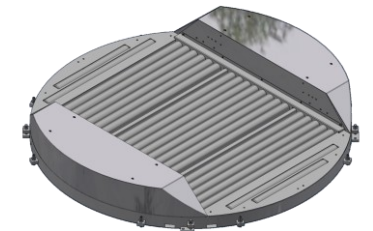

Product portfolio

Examples of our logistic portfolio, just a small overview

Pallet collector
/ dispenser

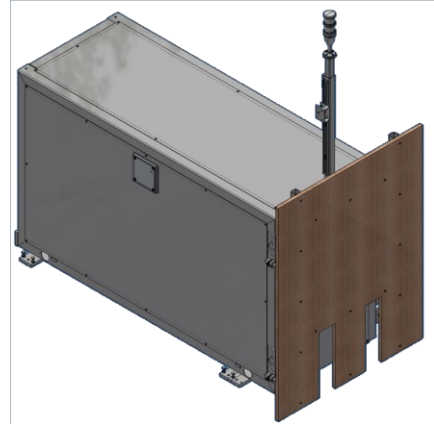

Lifting table
with conveyor

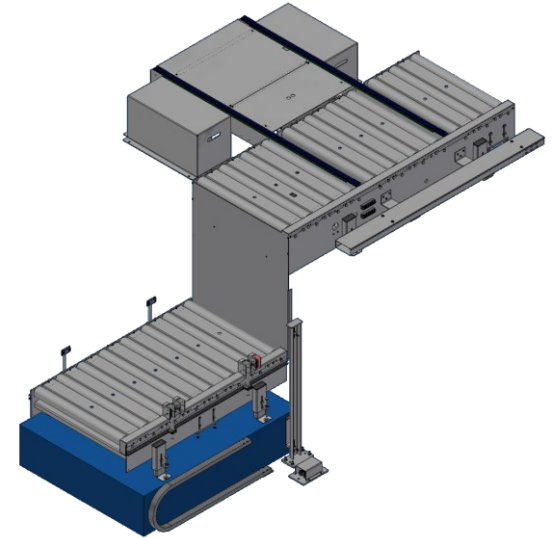

Transfer car

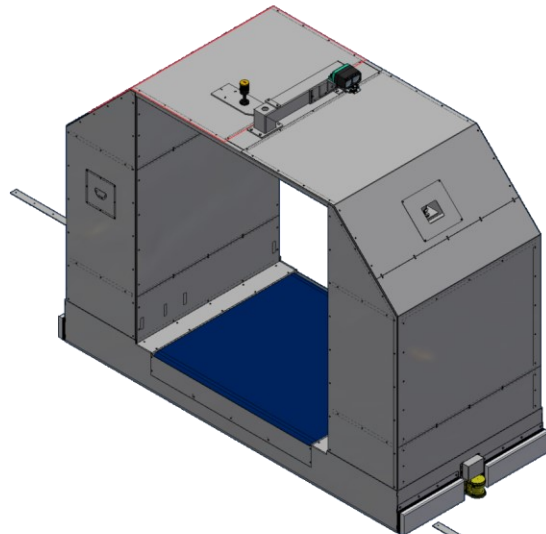

Pallet turner

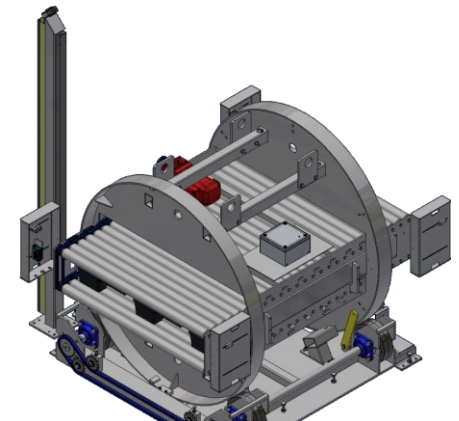

Product portfolio

Pile turner, different types

E-Modell

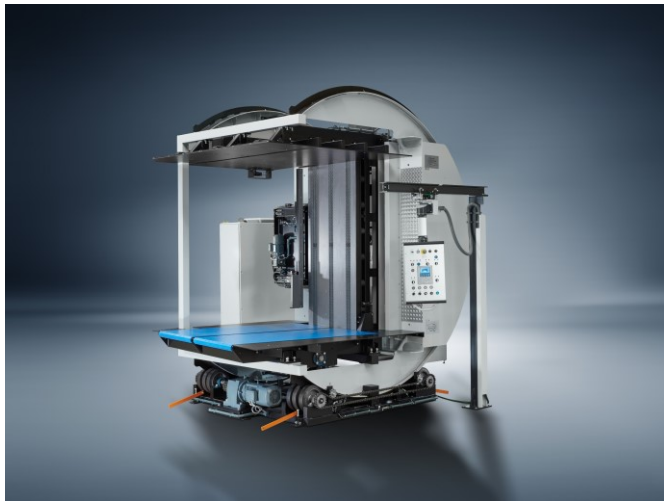

VB-Modell



VBH-Modell



Pile turners with conveyors for Integration into automatic logistic systems

Pile turner with roller conveyor and plastic belt conveyor

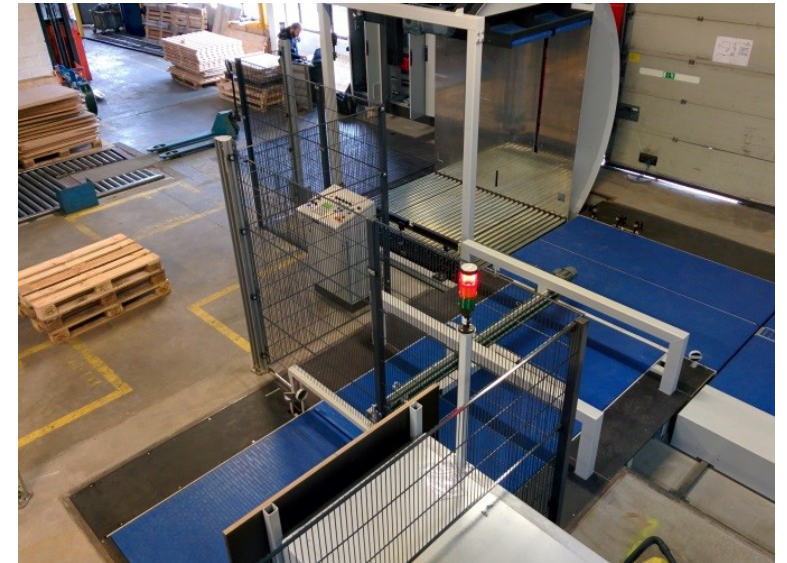
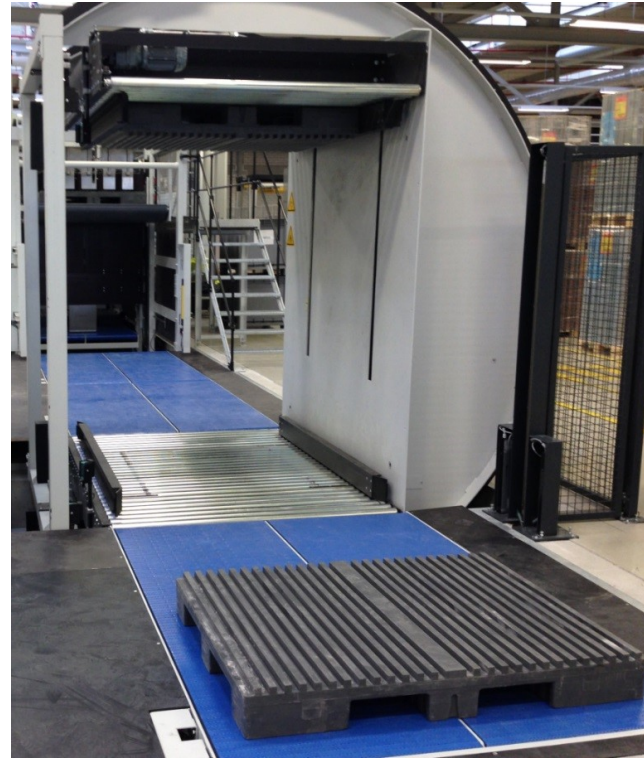

Pile turners with integrated logistics offer highest flexibility for integration into fully automated pile handling systems

Pile turners with integrated pallet dispensers and collectors



Most useful for printing machines with a non-stop feeding system where sheet piles need to be transported to the feeder on plastic system pallets



Innovations 2020 / 2021

New at product portfolio

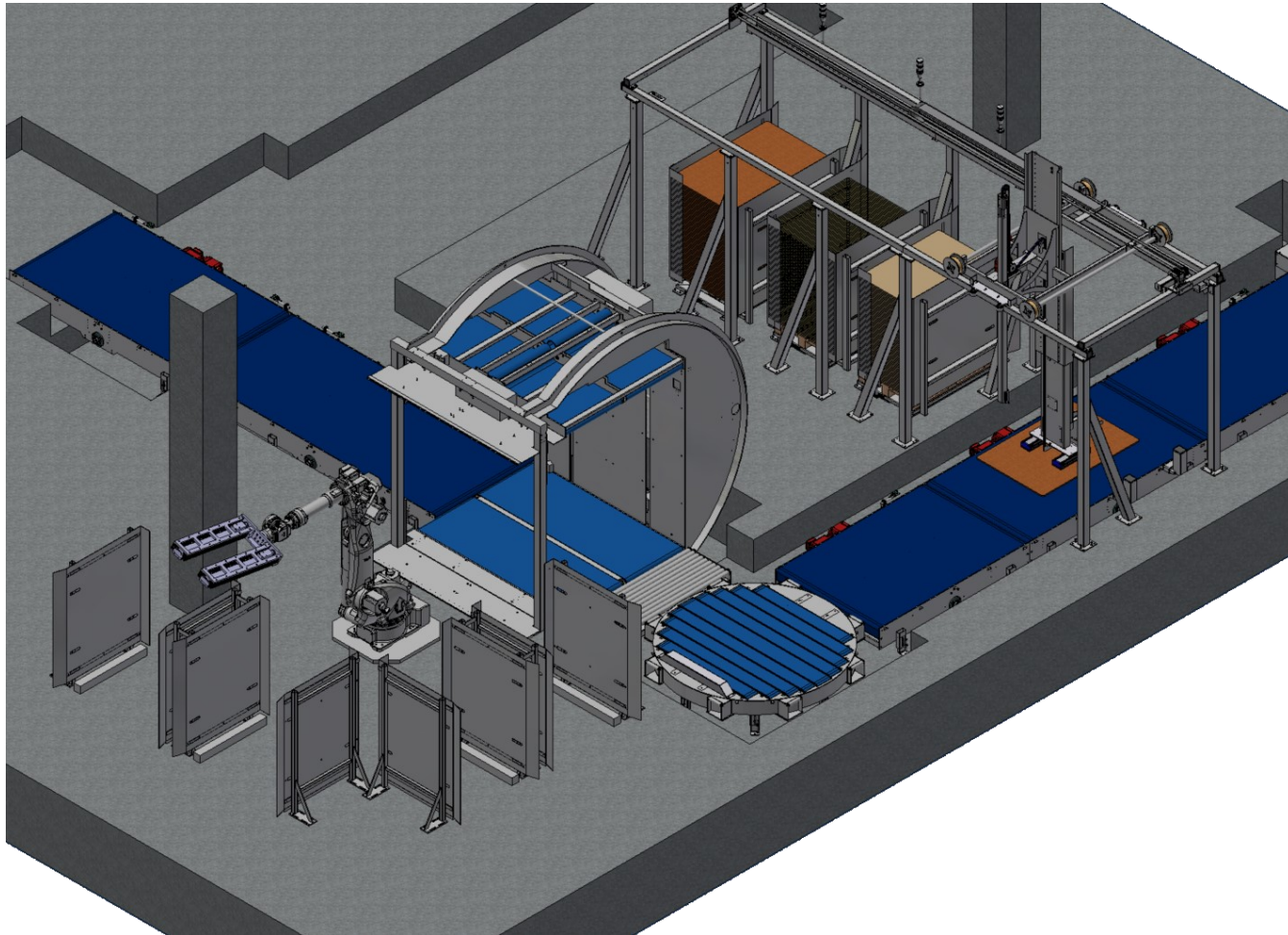

Pile turner E230KTBF/KTBF for
Format 3B & Format 6
Insertion of the empty pallet in the
centre of the paper stack by means of a
robot

Placing a plate on the stack by means of
plate handling

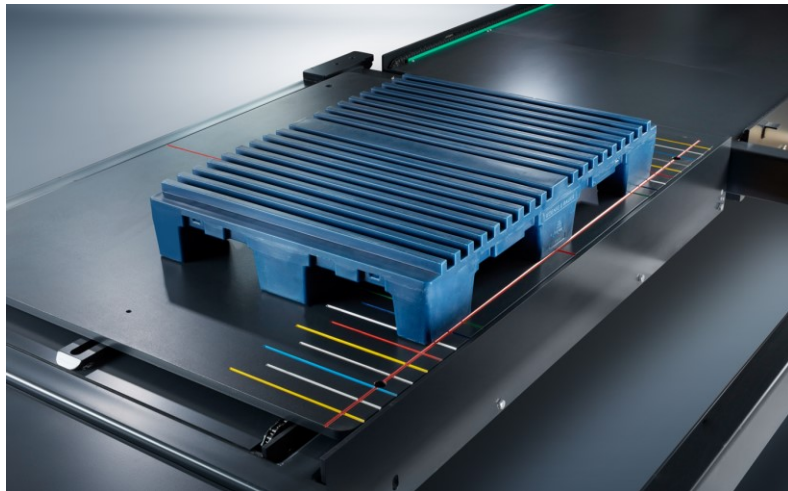
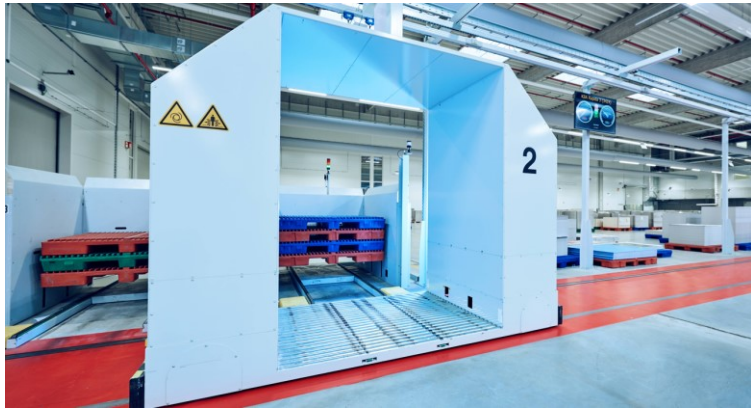



**Krifft
& Zipsner**
Maschinenbau

Professional conveyor systems & intelligent pile turners

**We move with
system !**

Many thanks for your attention

ppa. Rainer Ehlert

Sales manager / Authorized officer

Krifft & Zipsner GmbH

Contact:

Industriestraße 4/17

D-57520 Steinebach/Sieg

info@krifft-zipsner.de

www.krifft-zipsner.de